



HGS (INDIA) LIMITED



HGS 5515 Back to Back Connector



158, Sector-4, IMT Manesar, Gurugram-122050, Haryana, INDIA
Tel: +91 (0124) 4681800
Email: sales@hgsindia.com



HGS (INDIA) LIMITED



SCHEMATIC

HGS 5515 Back to Back Connector

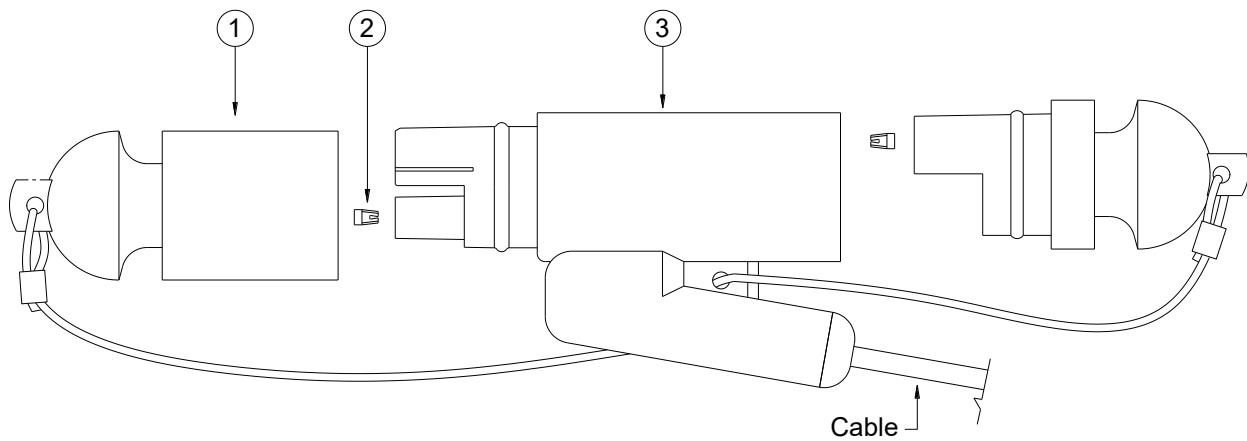

3	CONNECTOR BODY SUB ASSY.	01 No.
2	MILL-MAX #08	02 Nos.
1	MALE & FEMALE DUST CAP WITH WIRE ROPE & FERRULE	01 No.
S. NO.	DESCRIPTION	QTY



HGS (INDIA) LIMITED



SPECIFICATIONS

HGS 5515 Back to Back Connector

- Connector with back to back male & female connectors.
- Impact resistant material. Can be provided for cold weather use.
- Moulded on 4.57, 5.33 or 6.35 mm cable.
- Water proof for marsh environment.
- Gold plated pins & sockets assure positive electrical connections.
- Push-pull fit.
- Maximum strength in rugged field condition.
- Fitted with male and female dust cap.
- Operating Temperature Range: -20°C to +70°C.
- Pressure Rating: Up to 3 bar.

Version 1.2